

Black Vinyl Dipped  
0.69-0.89mm Coating Thickness

One Round Hole  
One Slotted Hole

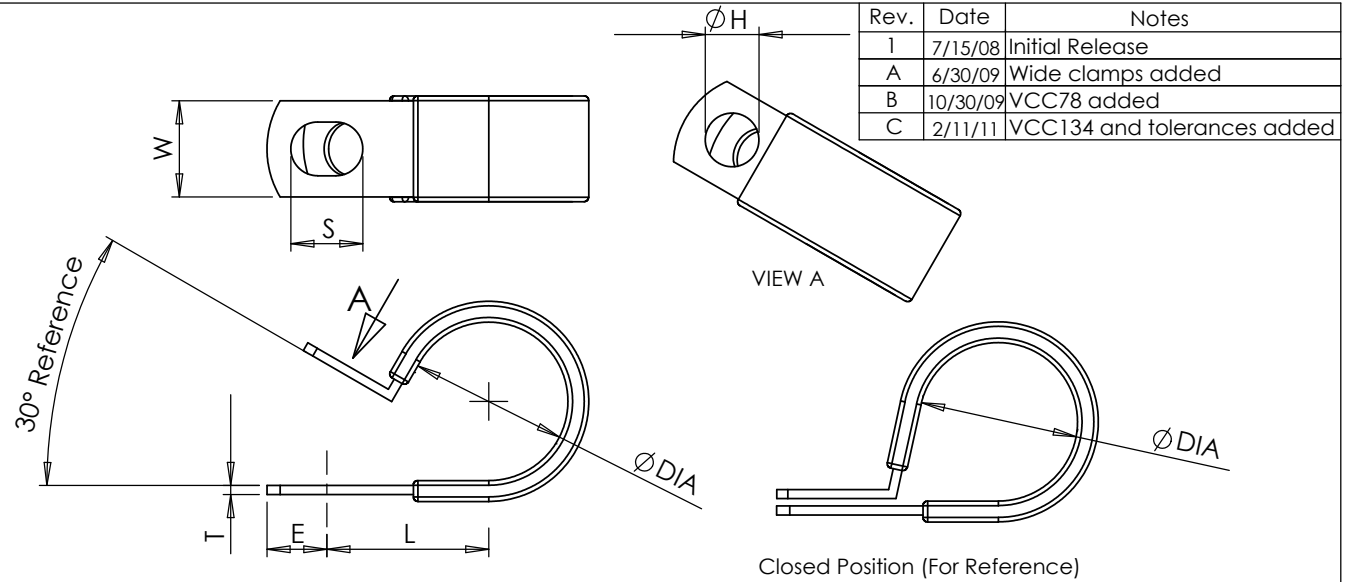
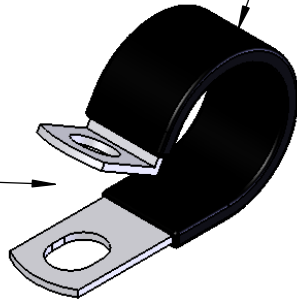

Rev.	Date	Notes
1	7/15/08	Initial Release
A	6/30/09	Wide clamps added
B	10/30/09	VCC78 added
C	2/11/11	VCC134 and tolerances added

Part #	DIA (+/-) 0.015 in	H (+/-) 0.005 in	T (+/-) 0.003 in	W (+/-) 0.010 in	S (+/-) 0.020 in	E (+/-) 0.015 in	L (+/-) 0.040 in
VCC14	1/4 in [6.35mm]	0.281 in [7.14mm]	0.032 in [0.81mm]	0.5 in [12.7mm]	0.375 in [9.53mm]	0.312 in [7.92mm]	0.531 in [13.49mm]
VCC38	3/8 in [9.53mm]	0.281 in [7.14mm]	0.032 in [0.81mm]	0.5 in [12.7mm]	0.375 in [9.53mm]	0.312 in [7.92mm]	0.593 in [15.06mm]
VCC12	1/2 in [12.7mm]	0.281 in [7.14mm]	0.048 in [1.22mm]	0.5 in [12.7mm]	0.375 in [9.53mm]	0.312 in [7.92mm]	0.656 in [16.66mm]
VCC58	5/8 in [15.88mm]	0.281 in [7.14mm]	0.048 in [1.22mm]	0.5 in [12.7mm]	0.375 in [9.53mm]	0.312 in [7.92mm]	0.718 in [18.24mm]
VCC34	3/4 in [19.05mm]	0.281 in [7.14mm]	0.048 in [1.22mm]	0.5 in [12.7mm]	0.375 in [9.53mm]	0.312 in [7.92mm]	0.781 in [19.84mm]
VCC78	7/8 in [22.25mm]	0.281 in [7.14 mm]	0.048 in [1.22mm]	0.5 in [12.7mm]	0.540 in [13.7 mm]	0.312 in [7.92mm]	0.844 in [21.4 mm]
VCC1	1 in [25.4mm]	0.281 in [7.14mm]	0.048 in [1.22mm]	0.5 in [12.7mm]	0.375 in [9.53mm]	0.312 in [7.92mm]	0.906 in [23.01mm]
VCC114	1 1/4 in [31.75mm]	0.281 in [7.14mm]	0.048 in [1.22mm]	0.5 in [12.7mm]	0.375 in [9.53mm]	0.312 in [7.92mm]	1.031 in [26.19mm]
VCC112	1 1/2 in [38.1mm]	0.281 in [7.14mm]	0.048 in [1.22mm]	0.5 in [12.7mm]	0.375 in [9.53mm]	0.312 in [7.92mm]	1.281 in [32.54mm]
VCC112W	1 1/2 in [38.1mm]	0.406 in [10.31mm]	0.048 in [1.22mm]	0.75 in [19.05mm]	0.500 in [12.7mm]	0.437 in [11.10mm]	1.281 in [32.54mm]
VCC134	1 3/4 in [44.5mm]	0.281 in [7.14mm]	0.048 in [1.22mm]	0.5 in [12.7mm]	0.375 in [9.53mm]	0.312 in [7.92mm]	1.422 in [36.11mm]
VCC2	2 in [50.8mm]	0.281 in [7.14mm]	0.048 in [1.22mm]	0.5 in [12.7mm]	0.375 in [9.53mm]	0.312 in [7.92mm]	1.562 in [39.67mm]
VCC2W	2 in [50.8mm]	0.406 in [10.31mm]	0.048 in [1.22mm]	0.75 in [19.05mm]	0.500 in [12.7mm]	0.437 in [11.10mm]	1.562 in [39.67mm]
VCC212W	2 1/2 in [63.5mm]	0.406 in [10.31mm]	0.048 in [1.22mm]	0.75 in [19.05mm]	0.500 in [12.7mm]	0.437 in [11.10mm]	1.812 in [46.03mm]
VCC3W	3 in [76.2mm]	0.406 in [10.31mm]	0.048 in [1.22mm]	0.75 in [19.05mm]	0.500 in [12.7mm]	0.437 in [11.10mm]	2.062 in [52.38mm]

**PROPRIETARY AND CONFIDENTIAL**  
THE INFORMATION CONTAINED IN THIS DRAWING IS THE SOLE PROPERTY OF **CAMBRIDGE RESOURCES**. ANY REPRODUCTION IN PART OR AS A WHOLE WITHOUT THE WRITTEN PERMISSION OF **CAMBRIDGE RESOURCES** IS PROHIBITED.

**Notes:**

1. HD Galvanized Steel, Chem-Treated G90 Per ASTM A653/A653M
2. Must be RoHS Compliant (Hexavalent Chromium Free)
3. Parts to be free of burrs and sharp edges

NAME	DATE	<h1 style="text-align: center;">CAMBRIDGE</h1> <p style="text-align: center;">960 Alabama Ave, Brooklyn, NY 11207 P:718-649-1666 F:718-485-4403</p>		
DRAWN	J Li			7/15/08
UNLESS OTHERWISE SPECIFIED:		TITLE:		
DIMENSIONS ARE IN INCHES [ ] DENOTES MILLIMETER TOLERANCES: x.xx ± .005in [0.13mm]		Vinyl Coated Clamps		
MATERIAL	FINISH	SIZE	DWG. NO.	REV
Galvanized Steel		<b>A</b>	VCC Clamps Rev C	<b>C</b>
DO NOT SCALE DRAWING		SCALE: 1:1		SHEET 1 OF 1