



# CAMBRIDGE SECURITY SEALS



## Ball Strap Seal

CAMBRIDGE RESOURCES  
960 ALABAMA AVE  
BROOKLYN, NY 11207  
(877) 922 2538  
INFO@CAMBRIDGESECURITYSEALS.COM

[WWW.CAMBRIDGESECURITYSEALS.COM](http://WWW.CAMBRIDGESECURITYSEALS.COM)

**STPBCAM**

# STPBCAM

**STPBCAM** is a durable steel strap manufactured with a secure locking chamber designed to provide a high level of security

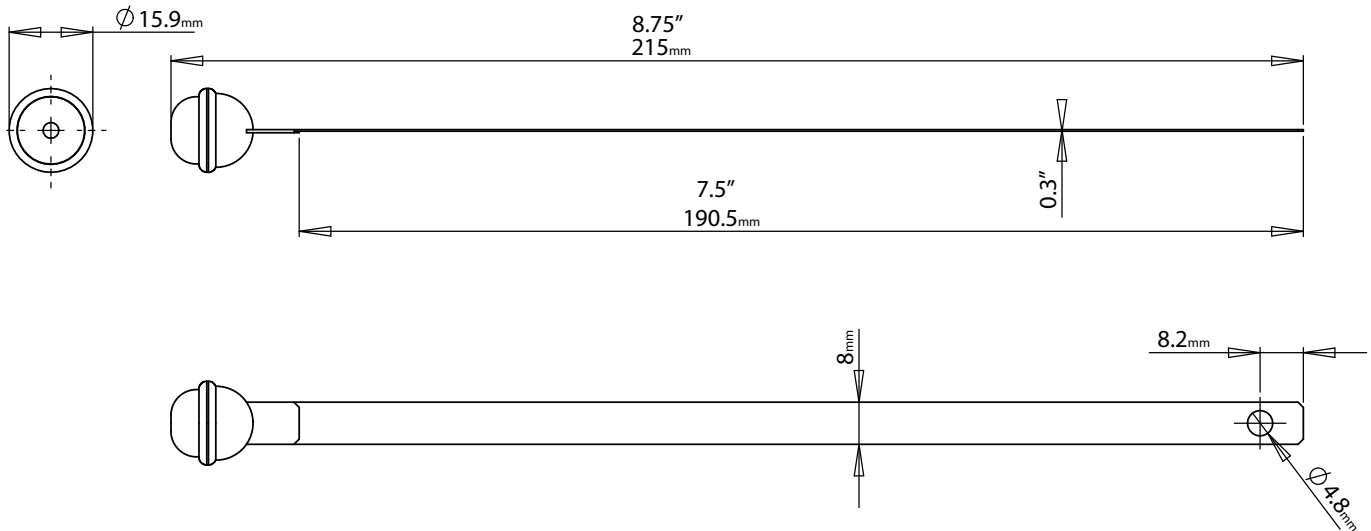

## Features:

- \* Easy to install
- \* Double locking barbs offer audible evidence of proper engagement and locking
- \* Embossed company name and logo
- \* Lock is protected by second metal cover

## Applications:

- \* Trailer doors
- \* Railroad cars
- \* Petrochemicals
- \* Inventory Control
- \* Food and Beverage
- \* Postal Service

## Materials:

- \* Locking Chamber: Tinplate
- \* Seal: Tinplate

## Length:

- \* Total Length: 8.75"

## Customization:

- \* Embossed Printing up to 12 characters
- \* Variable numbering up to 10 characters

## Tensile Strength:

Approx. 130 lbs.

## Packing:

50 seals per sealed Polybag  
1000 seals per Inner Carton  
2000 seals per Master Carton

## Box Dimensions:

**Inner Carton**  
12.5" X 11.5" X 7"

**Master Carton**  
13.5" X 12" X 14"

## Gross Weight:

**Inner Carton**  
15.5 lbs.

**Master Carton**  
31 lbs.

**SHOP ONLINE**



[www.cambridgesecurityseals.com](http://www.cambridgesecurityseals.com)



960 Alabama Ave, Brooklyn, NY 11207  
Ph: (718)927-0009 Fax: (718)485-4403  
info@cambridgeresources.com  
[www.cambridgeresources.com](http://www.cambridgeresources.com)