



# CAMBRIDGE SECURITY SEALS



## Adjustable Seal

CAMBRIDGE RESOURCES  
960 ALABAMA AVE  
BROOKLYN, NY 11207  
(877) 922 2538  
INFO@CAMBRIDGESECURITYSEALS.COM

[WWW.CAMBRIDGESECURITYSEALS.COM](http://WWW.CAMBRIDGESECURITYSEALS.COM)

**SLSCAM**

# SLSCAM

**SLSCAM** is a plastic, adjustable seal featuring a smooth round strap ideal for small-aperture applications.

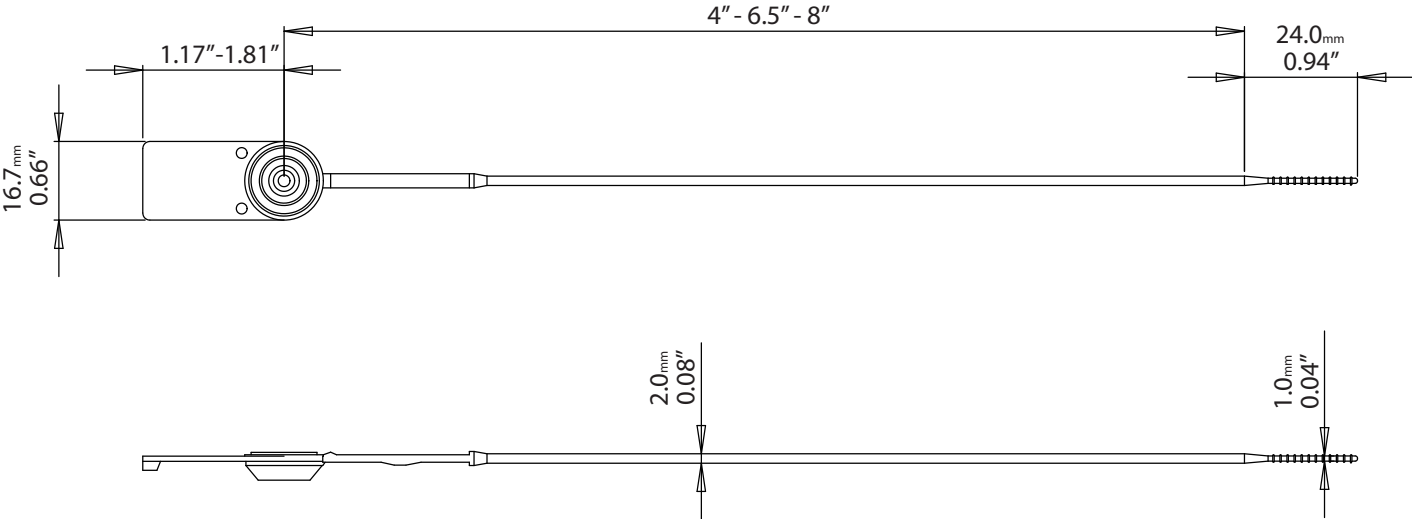

**Features:**

- \* Tamper evident design
- \* Stainless steel locking mechanism
- \* Smooth round strap

**Packing:**

10 seals per Strip  
 1000 seals per Inner Carton  
 5000 seals per Master Carton

**Applications:**

- \* Fiber drums
- \* Zippered money bags
- \* Cash boxes
- \* Plastic totes

**Box Dimensions:**

	Inner Carton	Master Carton
6.20"	10.5" x 7.5" x 6"	38.5" x 11" x 7"
8.5"	12.5" x 7.5" x 5"	38" x 13" x 6"
10"	12.5" x 7" x 6.5"	39" x 13" x 7.5"

**Materials:**

- \* Locking Chamber: Stainless Spring Steel
- \* Seal: Polypropylene

**Gross Weight:**

	Inner Carton	Master Carton
6.20"	3.5 lbs.	20 lbs.
8.5"	4 lbs.	21 lbs.
10"	4.25 lbs.	24 lbs.

**Length:**

- \* Total Length: 6.20", 8.5", 10"
- \* Usable Length: 4.20", 6.5", 8"

**Colors:**

- \* Red, Blue, Yellow, Green, White, Orange
- \* Other colors available upon request
- \* Hot stamped printing available in black or white

**Customization:**

- \* Customer name and logo (laser or foil)
- \* Consecutive numbering up to 7 characters

**Tensile Strength:**

- \* Approx. 29 lbs.

**SHOP ONLINE**   
[www.cambridgesecurityseals.com](http://www.cambridgesecurityseals.com)

 **CAMBRIDGE RESOURCES**  
 960 Alabama Ave, Brooklyn, NY 11207  
 Ph: (718)927-0009 Fax: (718)485-4403  
 info@cambridgeresources.com  
[www.cambridgeresources.com](http://www.cambridgeresources.com)