



CAMBRIDGE SECURITY SEALS



Fixed Length Seal

CAMBRIDGE RESOURCES
960 ALABAMA AVE
BROOKLYN, NY 11207
(877) 922 2538
INFO@CAMBRIDGESECURITYSEALS.COM

WWW.CAMBRIDGESECURITYSEALS.COM



INDICAM

INDICAM

INDICAM is a fixed length plastic trailer seal offering secure, reliable and easy to use security for trailers and transportation equipment.

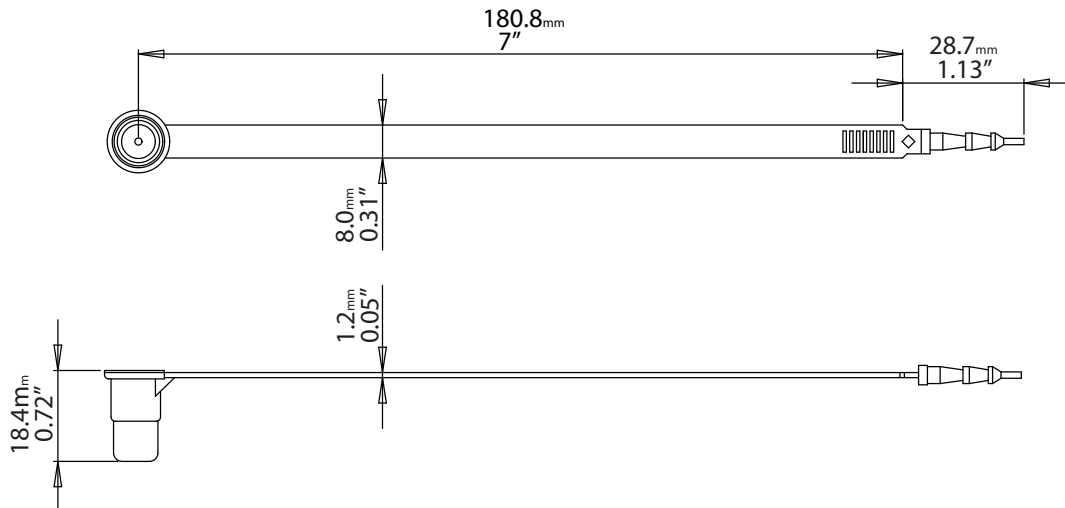

Features:

- * Double locking head and indicator tabs ensure proper closure
- * Easy to use and reliable
- * Visibly indicates tampering

Applications:

- * Trailer doors
- * Container doors
- * Bulk tankers
- * Plastic totes
- * Railroad cars

Materials:

- * Locking Chamber: Polyoxymethylene
- * Seal: Polypropylene

Length:

- * Total Length: 8"
- * Usable Length: 7"

Colors:

- * Hot Stamped: Red, Blue, Yellow, Green, White, Orange
- * Laser Printed: Yellow, White, Light Grey, Pink, Purple, Apricot
- * Other colors available upon request
- * Hot stamped printing available in black or white

Customization:

- * Customer name and logo printing (laser or foil)
- * Variable numbering up to 7 characters
- * Bar coding (laser)

Tensile Strength:

Approx. 25 lbs.

Packing:

10 seals per Strip
1000 seals per Inner Carton
5000 seals per Master Carton

Box Dimensions:

Inner Carton
14.25"X7.5"X8"

Master Carton
13" X 8" X 8.5"

Gross Weight:

Inner Carton
8 lbs.

Master Carton
40 lbs.

SHOP ONLINE



www.cambridgesecurityseals.com



960 Alabama Ave, Brooklyn, NY 11207
Ph: (718)927-0009 Fax: (718)485-4403
info@cambridgeresources.com
www.cambridgeresources.com