

Rev.	Date	Notes
A	11/01/09	Production revision

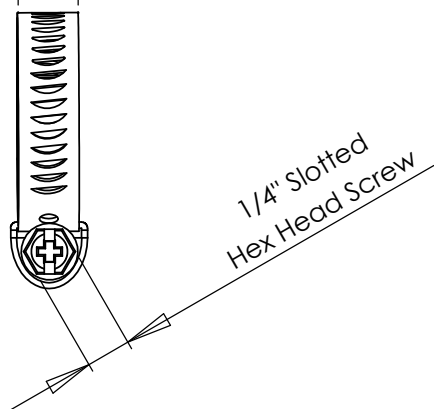

PART #	MIN DIA (MM)	MAX DIA (MM)
HCM-4S	7/32" (6)	5/8" (16)
HCM-6S	7/16" (11)	25/32" (20)

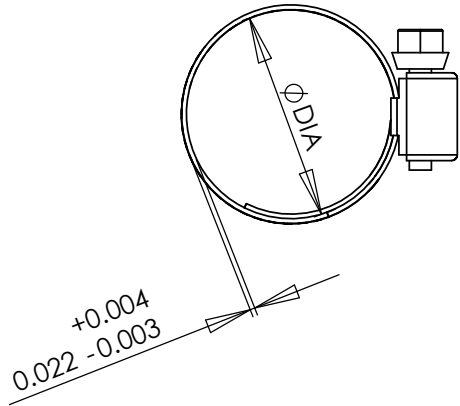
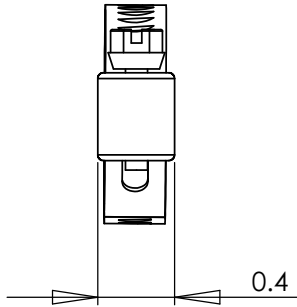

PROPRIETARY AND CONFIDENTIAL
 THE INFORMATION CONTAINED IN THIS DRAWING IS THE SOLE PROPERTY OF **CODA RESOURCES**. ANY REPRODUCTION IN PART OR AS A WHOLE WITHOUT THE WRITTEN PERMISSION OF **CODA RESOURCES** IS PROHIBITED.

Notes:

1. Meets SAE J1508 Specification
2. RoHS Compliant - No Hexavalent Chromium - Cr(VI)
3. Material: Band - 200 Series Stainless Steel
Screw and Housing - Zinc Plated
4. Screw Free Torque: 4 in·lbs Max
5. Max Install Torque: 20 - 25 in·lb
6. Durability Torque: 25 in·lbMin
7. All surface to be clean and polished
8. Parts to be free of burrs and sharp edges

NAME	DATE	CODA RESOURCES 960 Alabama Ave, Brooklyn, NY 11207 P:718-649-1666 F:718-485-4403	
DRAWN	J Li 6/1/05		
UNLESS OTHERWISE SPECIFIED:		TITLE:	
DIMENSIONS ARE IN INCHES [] DENOTES MILLIMETER Tolerances: .x.xx ± 0.02" x.xxx ± 0.005"		SERIES 1000, 5/16" BAND HOSE CLAMPS	
MATERIAL	SEE NOTES	SIZE	DWG. NO.
FINISH		A	HCM-XS Rev A
DO NOT SCALE DRAWING		SCALE: 1:1	WEIGHT:
			SHEET 1 OF 1