

Rev.	Date	Notes
A	1/21/09	Initial Release

Black Vinyl Dipped  
0.69-0.89mm Coating Thickness

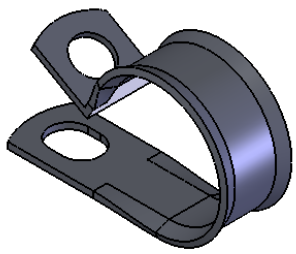

View of Flared Edges w/  
Vinyl Coating Removed

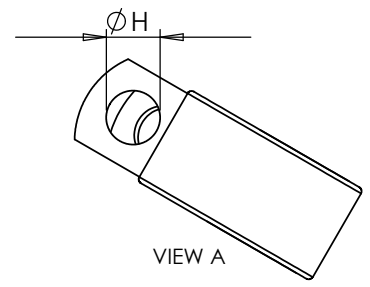
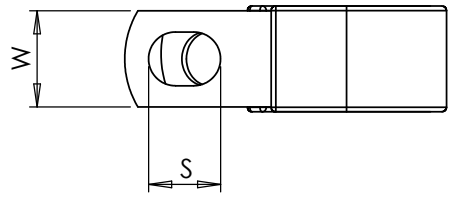
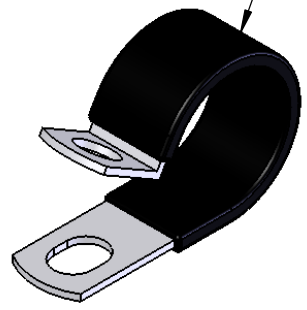
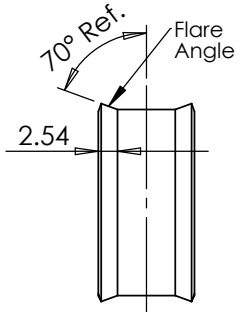

Section B-B  
Vinyl Coating Removed

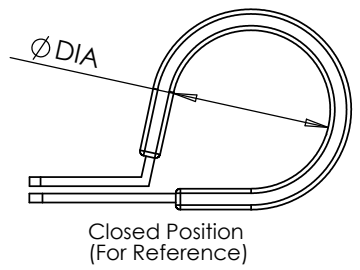
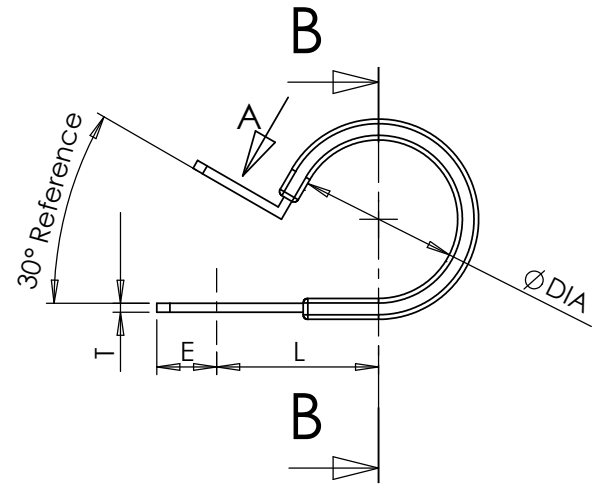

Closed Position  
(For Reference)

Part #	DIA	H	T	W	S	E	L
FEC12	1/2 in [12.7mm]	0.281 in [7.14mm]	0.048 in [1.22mm]	0.5 in [12.7mm]	0.375 in [9.53mm]	0.250 in [6.35mm]	0.656 in [16.66mm]
FEC58	5/8 in [15.88mm]	0.281 in [7.14mm]	0.048 in [1.22mm]	0.5 in [12.7mm]	0.375 in [9.53mm]	0.250 in [6.35mm]	0.718 in [18.24mm]
FEC34	3/4 in [19.05mm]	0.281 in [7.14mm]	0.048 in [1.22mm]	0.5 in [12.7mm]	0.375 in [9.53mm]	0.250 in [6.35mm]	0.781 in [19.84mm]
FEC78	7/8 in [22.25mm]	0.281 in [7.14mm]	0.048 in [1.22mm]	0.5 in [12.7mm]	0.375 in [9.53mm]	0.250 in [6.35mm]	0.843 in [21.41mm]
FEC1	1 in [25.4mm]	0.281 in [7.14mm]	0.048 in [1.22mm]	0.5 in [12.7mm]	0.375 in [9.53mm]	0.250 in [6.35mm]	0.906 in [23.01mm]



**PROPRIETARY AND CONFIDENTIAL**  
THE INFORMATION CONTAINED IN THIS DRAWING IS THE SOLE PROPERTY OF **CODA RESOURCES**. ANY REPRODUCTION IN PART OR AS A WHOLE WITHOUT THE WRITTEN PERMISSION OF **CODA RESOURCES** IS PROHIBITED.

- Notes:
1. HD Galvanized Steel, Chem-Treated G90 Per ASTM A653/A653M
  2. Must be RoHS Compliant (Hexavalent Chromium Free)

NAME	DATE	<b>CAMBRIDGE</b> 960 Alabama Ave, Brooklyn, NY 11207 P:718-649-1666 F:718-485-4403	
DRAWN	J Li 1/21/09		
UNLESS OTHERWISE SPECIFIED:		TITLE:	
DIMENSIONS ARE IN MILLIMETER TOLERANCES: x.xx ± .005in [0.13mm]		Flared Edge Vinyl Coated Clamps	
MATERIAL	FINISH	SIZE	DWG. NO.
Galvanized Steel		<b>A</b>	FEC Clamps Rev A
DO NOT SCALE DRAWING		SCALE: 1:1	REV <b>A</b>
			SHEET 1 OF 1